



WORLD LEADER IN FLEXIBLE SPACE MANAGEMENT

SUMMIT™



NEW
NEW
NEW
NEW
NEW

Vertical Lift

OPERABLE PARTITIONS



MOVING IN A NEW DIRECTION

NEW Summit[®]

VERTICAL LIFT OPERABLE PARTITIONS

Flexibility has a whole new direction...up.

Hufcor, the world's most installed brand of operable partitions, introduces the Summit 640V vertical lift operable wall system. Summit's patent-pending lift system takes acoustic operable panels and stacks them neatly above the ceiling. The unique, automated lifting device makes operation as simple as pushing a button to provide optimal space division.

FEATURES & BENEFITS

- **RETRACTS VERTICALLY ABOVE THE CEILING**
Benefit: Floor space is not needed to store the partition when it is not in the opening.
- **INTERLOCKING SEALS**
Benefit: Maintains acoustics over time, ensures panel-to-panel alignment, and adds stability to the partition when extended.
- **CONTACT SENSOR SEAL**
Benefit: Safety—Stops the downward movement and reverses the partition if it should encounter a person or object.
- **VERTICAL GUIDE RAILS**
Benefit: Reduces moveable parts and the need for separate motors to seal panel into opening.
Benefit: Easy access to operating guide rollers and safety limit switches for inspection and repair adjustments.
- **SAFETY SYSTEMS**
Benefit: Primary and secondary safety systems in the event a single safety system would fail.
- **MANUAL OVERRIDE OF MOTOR UNITS**
Benefit: Panels can be lowered if there is a power failure.
- **ELECTRONIC, AUTOMATIC OPERATION**
Benefit: Automated operation – reduces setup and operational training time.
- **DURABLE WELDED STEEL FRAMES**
Benefit: Proven durability in tens of thousands of Hufcor installations globally.
- **SINGLE PANEL CONSTRUCTION**
Benefit: Fewer moveable parts and aesthetically more appealing, creating a "wow" factor.



Photos are product representations.

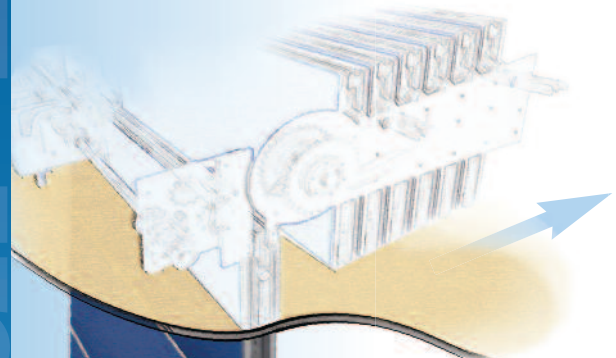

Summit[®]
by HUFCOR

The Summit[®] panels cascade individually through a narrow slot and then stack neatly above the ceiling.



FOR MORE INFORMATION VISIT www.hufcor.com

SUMMIT® OPERABLE PARTITION SPECIFICATIONS

Panel Construction

Panels are a nominal 4" [102] thick and to 30" [762] in height. Panel faces shall be steel laminated to appropriate substrate to meet the STC requirement. Welded steel frames are of minimum 16 gauge [1.42mm] painted steel.

Seals

Sound seals shall be of tongue and groove configuration, ensure panel-to-panel alignment and prevent sound leaks between panels.

Horizontal panel edges shall provide a minimum groove appearance.

The first panel in the opening shall have a bottom retractable safety sensor seal providing a minimum of 2" [51] floor adjustability to accommodate out-of-level floors.

Finishes

The standard face finish is factory-applied vinyl; however, optional carpet, fabric, and other custom finishes are available, subject to factory approval for manufacturing compatibility.

Exposed metal trim is powder coated in Lamb's Wool, Gray, Brown, or clear anodized aluminum. The matching vinyl seals are available in Lamb's Wool, Gray, or Brown. Custom metal trim colors are available for an upcharge.

IMPORTANT NOTE ABOUT FACE FINISH DIRECTION: Finishes will be applied to the 640V IN A HORIZONTAL DIRECTION. The finishes provided on most selectors or samples are shown in a vertical position and may look different when applied horizontally.

Motor and Drive System

Panels are retracted above the ceiling and stored by activating the two key-switch controls. The motor and drive system shall automatically extend/retract the panels in the opening.

Each panel shall be supported by two guide rollers traveling in vertical guide rails.

Power unit and controls shall be UL listed. Motor shall have adequate horsepower to operate partition effectively. Partition shall be operated by two (2) control stations wired in series and located on opposite sides and ends of the partition. The key stations require human contact to be activated ensuring safe, supervised operation of the partition system.

Safety Systems

When the operable wall is being lowered (closed), the panels shall stop and reverse if the leading (bottom) edge comes into contact with any object between it and the floor. The operation of the wall may resume once the key switch has been released and the obstruction cleared.

Acoustics

The partition has been tested at a laboratory accredited by the National Voluntary Laboratory Accreditation Program (NVLAP) and in accordance with ASTM E90 Test Standards. Standard panel construction shall have obtained a minimum STC rating of 51.

Weight

Weight of the panels shall be 10.9 lbs. per sq. ft. [53.2 kg/sq m],

ISO Registration

Hufcor U.S. manufacturing facilities' quality systems are registered to the ISO 9001 standards.

Warranty

Summit Series 640V partitions are guaranteed for two years against defects in material and workmanship, excluding abuse.

Details and editable specifications can be downloaded from Hufcor's website, www.hufcor.com. Complete specifications and details may also be found in our Architectural Product Manual.

640V SERIES VERTICAL SECTION

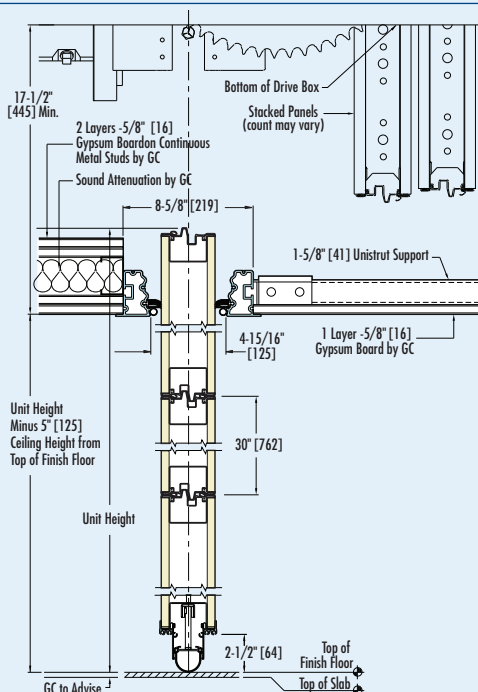

640V HORIZONTAL SECTIONS

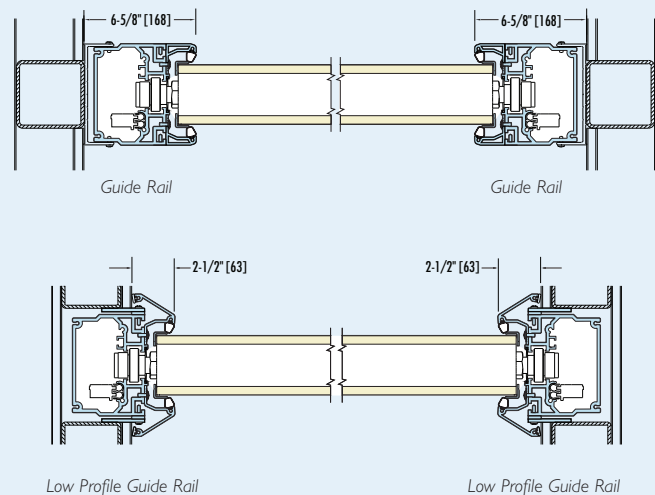

BIM MODEL NOW AVAILABLE FOR THE 640V SUMMIT.
CONTACT YOUR LOCAL HUF COR DISTRIBUTOR FOR ASSISTANCE.

Note: Metric dimensions are in []

Choose Hufcor...

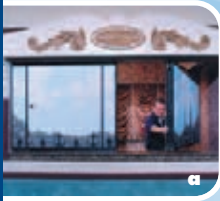

a This busy banquet facility uses short partitions to close off the bar when it is not needed. The vinyl faces were hand painted to match the permanent walls.

b Beautiful wood wainscot and chair rails were added to the panels to match the perimeter walls.

c Dividing auditoriums and meeting rooms with stairs is not a problem for Hufcor. Our bottom seals are modified to seal perfectly against each step.

Partitions must control sound. We test our products in our sound laboratory to make certain they meet or exceed our published acoustical ratings. The laboratory is certified by the National Voluntary Laboratory Accreditation Program (NVLAP) and, like our ISO certification, we undergo regular inspection to make certain we adhere to their strict regulations. And, although it isn't required of us, we also hire an independent consultant to witness and verify any test results.

Worldwide Availability. Hufcor's U.S. manufacturing facility is located at our headquarters in Janesville, Wisconsin. In addition, Hufcor products are manufactured in Australia, Brazil, Canada, China, Finland, France, Germany, Japan, Malaysia, Mexico, Russia, South Africa, Spain, and the

AND CHOOSE PARTITIONS THAT ARE KNOWN WORLDWIDE FOR QUALITY AND VALUE.

United Arab Emirates. Hufcor products may be purchased through a network of authorized Distributors located throughout the world. Check our website or call for the name of your nearest representative.

Renovation and Repair. Not only do we provide new products, we also offer retrofit service for Hufcor products and those manufactured by others. Contact your local Hufcor representative for a free analysis of your needs.

Leasing Program. You may wish to consider the option of buying partitions through a lease program. Check with your accountant to see if leasing vs. a lump sum payment will provide you with financial benefits.

Hufcor Custom Delivery. If you need to pinpoint the delivery date and time (which is often critical for renovation projects), we can do it. In the U.S., our fleet of vans can deliver your order on time and without damage that can occur when shipping by other methods.

innovation YOU GET MORE WITH HUFCOR



WORLDWIDE HEADQUARTERS
PO Box 591 / 2101 Kennedy Road, Janesville, WI 53547
Toll-Free: 800-542-2371, ext. 214 Telephone: 608-756-1241
Fax: 608-758-8253 E-mail: info@hufcor.com
www.hufcor.com

The Hufcor Commitment to Green Manufacturing, Sustainability and LEED™. Hufcor is committed to being an industry leader when it comes to protecting the environment by reducing pollutants and minimizing our environmental impact on air, water and land. For over a decade Hufcor has utilized a "Green" approach to manufacturing and energy consumption and has increased the percentage of materials that we recycle, reuse, repair, restock or return for salvage. Today, the Hufcor commitment and progress toward Green manufacturing is greater than ever as we continue to develop standards that support various LEED™ (Leadership in Energy and Environmental Design) points to assist the achievement of LEED certification goals.



IT'S ALL IN THE BOOK
More details on all Hufcor products are available in the Architectural Product Manual. Call your local rep today to receive a complimentary copy.

see us at
Sweets.com

Hufcor has a program of continuous product improvement. As a result, some products may be modified from those represented in this catalog.

Hufcor Partition U.S. Patents:			
2,861,660	3,056,193	3,223,147	3,295,257
3,295,588	3,450,185	3,638,376	3,755,968
3,783,930	3,879,799	3,042,960	4,014,137
5,181,296	5,230,123	5,406,676	5,481,834
5,564,759	6,112,466	6,167,937	



The quality systems of Hufcor's U.S. manufacturing facilities are registered to the ISO 9001 standards.



*USGBC and related logo is a trademark owned by the U.S. Green Building Council and is used by permission.



Hufcor offers continuing education programs for AIA members. Contact your Hufcor representative for details.